

VOR RWY 14 (GNSS)

OTTAWA/MACDONALD-CARTIER INTL
OTTAWA ON

ATIS (Eng) 121.15 265.6 (Fr) 132.95 382.05	ARR OTTAWA ARR 135.15 247.0	OTTAWA TWR 118.8 236.6	OTTAWA GND 121.9 275.8	DEP OTTAWA DEP 128.175 252.5	ELEV 374 TDZE 14 367
---	---	----------------------------------	----------------------------------	--	---------------------------------------

CYW

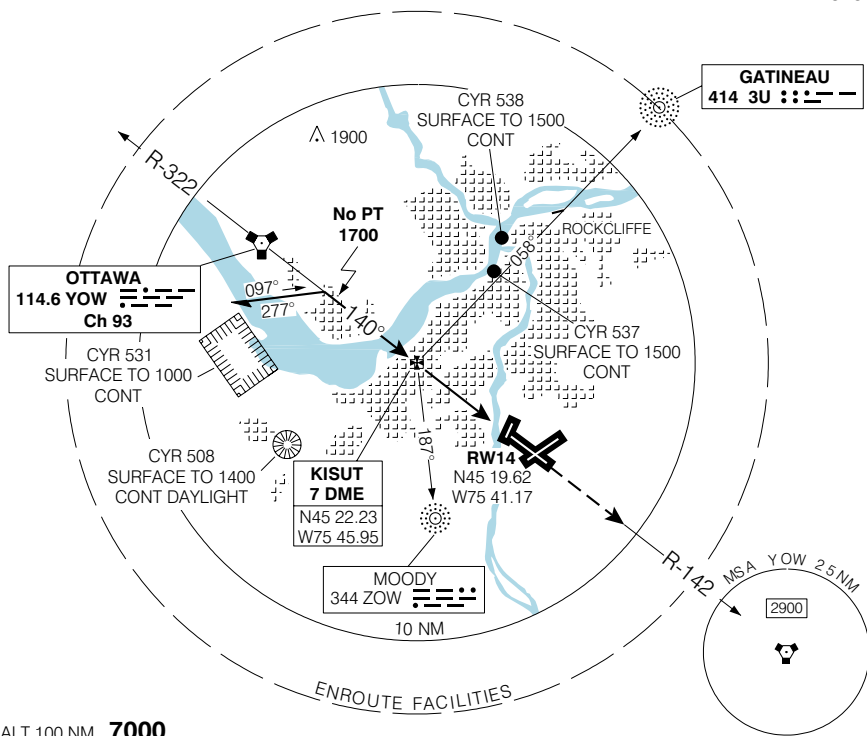

SAFE ALT 100 NM **7000**

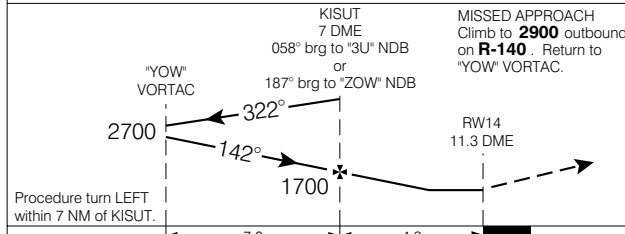

Right hand circuits
Runways 07, 14 & 22
Rwy 04-22: 3300 X 75

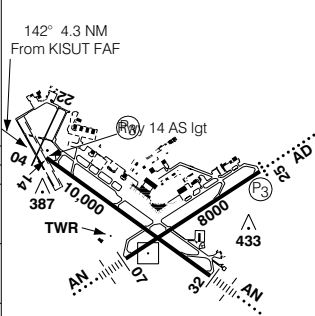

CATEGORY	A	B	C	D
VOR/DME VOR/NDB	900	(533)	1 ¾	
CIRCLING	900 (526)	1 ¾	900 (526) 2	1080 (706) 2 ½

FAF to MAP 4.3 NM				
Knots	70	90	110	130 150
Min:Sec	3:41	2:52	2:21	1:59 1:43

VOR RWY 14 (GNSS)

N45 19 21 W75 40 09

VAR 14° W
OTTAWA ON
OTTAWA/MACDONALD-CARTIER INTL

EFF 13 APR 06 CHANGE: GPS to GNSS

NAD83

© 2006 Her Majesty The Queen in Right of Canada, Department of Natural Resources. All rights reserved. Source of Canadian Civil Aeronautical Data: © 2006 NAV CANADA. All rights reserved.